

**Zavod za gradbeništvo
Slovenije**
**Slovenian National Building and
Civil Engineering Institute**
Dimičeva 12,
1000 Ljubljana, Slovenija
Tel.: +386 (0)1-280 44 72
Fax: +386 (0)1-436 74 49
e-mail: info.ta@zag.si
<http://www.zag.si>

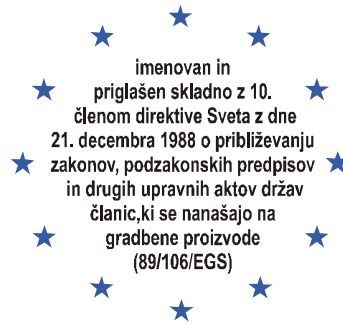

član EOTA

European Technical Approval

ETA-10/0425

[English translation prepared by ZAG – Original version in Slovenian language]

Komercialno ime
Trade name

FM-X5

Imetnik soglasja
Holder of approval

FRIULSIDER S.p.A.
via Trieste, 1
33048 San Giovanni al Natisone (UD)
Italy

Tip gradbenega proizvoda in njegova
predvidena uporaba

**Plastično sidro za skupinsko nekonstrukcijsko
uporabo v betonu in zidakih**

*Generic type and use
of construction product*

*Plastic anchor for multiple use in concrete and masonry
for non- structural applications*

Veljavnost od
Validity from
do
to

21.02.2012
13.12.2015

Proizvodni obrat
Manufacturing plant

FRIULSIDER S.p.A.
via Trieste, 1
33048 San Giovanni al Natisone (UD)
Italy

To soglasje zamenjuje:

ETA-10/0424 veljavno od 30.05.2011 do
13.12.2015

This Approval replaces

*ETA-10/0424 with validity from 30.05.2011 to
13.12.2015*

To Evropsko tehnično soglasje vsebuje

28 strani vključno s 17 prilogami, ki so sestavni del
tega soglasja.

*This European Technical Approval
contains:*

*28 pages including 17 annexes which form an integral
part of the document.*



Evropska organizacija za tehnična soglasja
European Organisation for Technical Approvals

I LEGAL BASES AND GENERAL CONDITIONS

1. This European Technical Approval is issued by the Slovenian National Building and Civil Engineering Institute (ZAG) in accordance with:
 - Council Directive 89/106/EEC of 21 December 1988 on the approximation of laws, regulations and administrative provisions of Member States relating to construction products¹, modified by the Council Directive 93/68/EEC² and regulation (EC) N°1882/2003 of the European Parliament and of the Council³,
 - Zakon o gradbenih proizvodih – ZGPro (Ur. List, št. 52/00 in 110/02) “Construction Product Act – ZGPro (OG RS N° 52/00 and 110/02)”,
 - Common Procedural Rules for Requesting, Preparing and the Granting of European Technical Approvals set out in the Annex of Commission Decision 94/23/EC⁴,
 - Guideline for European Technical Approval of “Plastic Anchors for Multiple Use in Concrete and Masonry for Non-structural Applications”, ETAG 020: Parts 1, 2 3 and 4 edition March 2006.
2. The Slovenian National Building and Civil Engineering Institute (ZAG) is authorised to check whether the provisions of this European Technical Approval are met. Checking may take place in the manufacturing plant. Nevertheless, the responsibility for the conformity of the products with the European Technical Approval and for their fitness for the intended use remains with the holder of the European Technical Approval.
3. This European Technical Approval is not to be transferred to manufacturers or agents of manufacturer other than those indicated on page 1; or manufacturing plants other than those indicated on page 1 of this European Technical Approval.
4. This European Technical Approval may be withdrawn by the Slovenian National Building and Civil Engineering Institute (ZAG), in particular pursuant to information by the Commission according to Article 5 (1) of the Council Directive 89/106/EEC.
5. Reproduction of this European Technical Approval including transmission by electronic means shall be in full. However, partial reproduction can be made with the written consent of the Slovenian National Building and Civil Engineering Institute (ZAG). In this case partial reproduction has to be designated as such. Texts and drawings of advertising brochures shall not contradict or misuse the European Technical Approval.
6. The European Technical Approval is issued by the approval body in its official language. This version corresponds fully to the version circulated within EOTA. Translations into other languages have to be designated as such.

¹ Official Journal of the European Communities N° L 40, 11.2.1989, p.12

² Official Journal of the European Communities N° L 220, 30.8.1993, p.1

³ Official Journal of the European Union N° L 284, 31.10.2003, p.1

⁴ Official Journal of the European Communities N° L 17, 20.1.1994, p.34

II SPECIFIC CONDITIONS OF THE EUROPEAN TECHNICAL APPROVAL

1 Definition of product and intended use

1.1 Definition of product

The FM-X5 is a plastic anchor consisting of a plastic sleeve made of polyamide and an accompanying specific screw of galvanized steel or of stainless steel.

The plastic sleeve is expanded by screwing in the specific screw which presses the sleeve against the wall of the drilled hole.

The installed anchor is shown in Annex 1.

1.2 Intended use

The anchor is intended to be used for anchorages for which requirements for safety in use in the sense of the Essential Requirement 4 of Council Directive 89/106/EEC shall be fulfilled and failure of the fixture represents an immediate risk to human life.

The anchor is to be used only for multiple fixing for non-structural applications in concrete and masonry. The base material shall consist of reinforced or unreinforced normal weight concrete of strength class C12/15 at minimum according to EN 206-1:2003, masonry walls according to Annex 4 and non-cracked autoclaved concrete according to Annex 4. The anchor may be used in cracked and non-cracked concrete. The mortar strength class of the masonry has to be M2,5 according to EN 998-2:2003 at minimum.

By multiple anchor use it is assumed that in the case of excessive slip or failure of one anchor the load can be transmitted to neighboring anchors without significantly violating the requirements on the fixture in the serviceability and ultimate limit state.

Therefore the design of the fixture may specify the number n_1 of fixing points to fasten the fixture and the number n_2 of anchors per fixing point. Furthermore by specifying the design value of actions N_{Sd} on a fixing point to a value $\leq n_3$ (kN) up to which the strength and stiffness of the fixture are fulfilled and the load transfer in the case of excessive slip or failure of one anchor need not to be taken into account in the design of the fixture.

The following default values for n_1 , n_2 and n_3 may be taken:

$$n_1 \geq 4; n_2 \geq 1 \text{ and } n_3 \leq 4,5 \text{ kN} \quad \text{or}$$

$$n_1 \geq 3; n_2 \geq 1 \text{ and } n_3 \leq 3,0 \text{ kN}.$$

The specific screw made of galvanized steel may only be used in structures subject to dry internal conditions.

The anchor may also be used in concrete with requirements related to resistance to fire according 4.2.1.2.

The specific screw made of stainless steel may be used in structures subject to dry internal conditions and also in structures subject to external atmospheric exposure (including industrial and marine environment), or exposure in permanently damp internal conditions, if no particular aggressive conditions exist. Such particular aggressive conditions are e. g. permanent, alternating immersion in seawater or the splash zone of seawater, chloride atmosphere of indoor swimming pools or atmosphere with extreme chemical pollution (e. g. in desulphurization plants or road tunnels where de-icing materials are used).

The specific screw made of galvanized steel may also be used in structures subject to external atmospheric exposure or exposure in permanently damp internal conditions, if the area of the head

of the screw is protected against moisture and driving rain after mounting of the fixing unit in this way, that intrusion of moisture into the anchor shaft is prevented. Therefore there shall be an external cladding or a ventilated rain screen mounted in front of the head of the screw and the head of the screw itself shall be coated with a soft plastic, permanently elastic bitumen-oil combination coating (e. g. undercoating or body cavity protection for cars).

The anchor may be used in the following temperature range:

Temperature range a):	-40 °C to +40 °C	(max long term temperature +24 °C and max short term temperature +40 °C)
Temperature range b):	-40 °C to +80 °C	(max long term temperature +50 °C and max short term temperature +80 °C)

The provisions made in this European Technical Approval are based on an assumed working life of the anchor of 50 years. The indications given on the working life cannot be interpreted as a guarantee given by the producer, but are to be regarded only as a means for choosing the right products in relation to the expected economically reasonable working life of the works.

2 Characteristics of product and methods of verification

2.1 Characteristics of product

The anchor corresponds to the drawings and information given in Annex 2 and 3. The characteristic material values, dimensions and tolerances of the anchor not indicated in these Annexes shall correspond to the respective values laid down in the technical documentation⁵ of this European Technical Approval.

The characteristic anchor values for the design of anchorage are given in Annex 4 Annexes 8 to 14 and in Annex 16.

Each anchor is to be marked with the identifying mark of the producer, anchor type, the diameter, length and maximum thickness of the fixture. For an example X5 ϕ 10 × 100 \Leftrightarrow 30 \Rightarrow . The minimum embedment depth should also be marked.

The anchor shall only be packaged and supplied as a complete unit.

2.2 Methods of verification

The assessment of the fitness of the anchor for the intended use in relation to the requirements for safety in use in the sense of the Essential Requirement 4 has been made in compliance with the Guideline for European Technical Approval of "Plastic Anchors for Multiple Use in Concrete and Masonry for Non-structural Applications", ETAG 020,

- Part 1: "General",
- Part 2: "Plastic Anchors for Use in Normal Weight Concrete",
- Part 3: "Plastic Anchors for Use in Solid Masonry Materials",
- Part 4: "Plastic Anchors for Use in Hollow or Perforated Masonry",
- Part 5: "Plastic Anchors for use in Autoclaved Aerated Concrete".

based on the use categories a, b, c and d.

⁵ The technical documentation of this European Technical Approval is deposited at the Slovenian National Building and Civil Engineering Institute (ZAG) and, as far as relevant for the tasks of the approved bodies involved in the attestation of conformity procedure, is handed over the approved bodies.

In addition to the specific clauses relating to dangerous substances contained in this European Technical Approval, there may be other requirements applicable to the products falling within its scope (e. g. transposed European legislation and national laws, regulations and administrative provisions). In order to meet the provisions of the Construction Products Directive, these requirements need also to be complied with, when and where they apply.

3 Evaluation and attestation of conformity and CE marking

3.1 System of attestation of conformity

According to the decision 97/463/EC of the European Commission⁶ the system 2+ of attestation of conformity applies.

This system of attestation of conformity is defined as follows:

System 2+: Declaration of conformity of the product by the manufacturer on the basis of:

- a) tasks for the manufacturer:
 - (1) initial type-testing of the product;
 - (2) factory production control;
 - (3) testing of samples taken at the factory by the manufacturer in accordance with a prescribed test plan.
- b) tasks for the approved body:
 - (4) certification of factory production control on the basis of:
 - initial inspection of factory and of factory production control;
 - continuous surveillance, assessment and approval of factory production control.

3.2 Responsibilities

3.2.1 Tasks of the manufacturer

3.2.1.1 Factory production control

The manufacturer shall exercise permanent internal control of production. All the elements, requirements and provisions adopted by the manufacturer are documented in a systematic manner in the form of written policies and procedures, including records of results performed. This production control system ensures that the product is in conformity with the European technical approval.

The manufacturer shall only use raw materials stated in the technical documentation of this European technical approval.

The factory production control shall be in accordance with the "Control Plan" of 13.12.2010 relating to the European technical approval ETA-10/0425 issued on 21.02.2012, which is part of the technical documentation of this European technical approval. The "Control Plan" is laid down in the context of the factory production control system operated by the manufacturer and deposited at the Slovenian National Building and Civil Engineering Institute (ZAG).

The results of factory production control shall be recorded and evaluated in accordance with the provisions of the "Control Plan".

3.2.1.2 Other tasks of the manufacturer

The manufacturer shall, on the basis of a contract, involve a body which is approved for the tasks referred to in a section 3.1 in the field of anchors in order to undertake the actions laid down in section 3.2.2. For this purpose the "Control Plan" referred to in sections 3.2.1.1 and 3.2.2 shall be handed over by the manufacturer to the approved body or bodies involved.

The manufacturer shall make a declaration of conformity, stating that the construction product is in conformity with the provisions of the European technical approval ETA–10/0425 issued on 21.02.2012.

3.2.2 Tasks of approved bodies

The approved body shall perform the:

- initial inspection of factory and of factory production control,
- continuous surveillance, assessment and approval of factory production control,

in accordance with the provisions laid down in the "Control plan" of 13.12.2010 relating to the European technical approval ETA–10/0425 issued on 21.02.2012.

The approved body shall retain the essential points of its actions referred to above and state the results obtained and conclusions drawn in a written report.

The approved certification body involved by the manufacturer shall issue an EC certificate of conformity of the factory production control stating the conformity with the provisions of this European technical approval.

In cases where the provisions of the European technical approval and its "Control Plan" are no longer fully filled the certification body shall withdraw the certificate of conformity and inform the Slovenian National Building and Civil Engineering Institute (ZAG) without delay.

3.3 CE-Marking

The CE marking shall be affixed on each packaging of anchors. The symbol "CE" shall be followed by the identification number of the approved certification body and be accompanied by the following additional information:

- the name and address of the manufacturer
- the last two digits of the year in which the CE-marking was affixed,
- the number of the EC certificate for the factory production control,
- number of the European technical approval,
- the number of the guideline for European technical approval,
- the identification number of the certification body,
- use category a, b, c and d.

4 Assumptions under which the fitness of the product for the intended use was favourably assessed

4.1 Manufacturing

The European technical approval is issued for the product on the basis of agreed data/information, deposited with the Slovenian National Building and Civil Engineering Institute (ZAG), which identifies the product that has been assessed and judged. Changes to the product or production process, which could result in this deposited data/information being incorrect, should be notified to the Slovenian National Building and Civil Engineering Institute (ZAG) before the changes are introduced. The Slovenian National Building and Civil Engineering Institute (ZAG) will decide whether or not such changes affect the ETA and consequently the validity of the CE marking on

the basis of the ETA and if so whether further assessment or alternations to the ETA, shall be necessary.

4.2 Installation

4.2.1 Design of anchorages

4.2.1.1 General

The anchor is to be used only for multiple fixing for non-structural applications. By multiple anchor use it is assumed that in the case of excessive slip or failure of one anchor the load can be transmitted to neighboring anchors without significantly violating the requirements on the fixture in the serviceability and ultimate limit state.

Therefore the design of the fixture may specify the number n_1 of fixing points to fasten the fixture and the number n_2 of anchors per fixing point. Furthermore by specifying the design value of actions N_{Sd} on a fixing point to a value $\leq n_3$ (kN) up to which the strength and stiffness of the fixture are fulfilled and the load transfer in the case of excessive slip or failure of one anchor need not to be taken into account in the design of the fixture.

The following default values for n_1 , n_2 and n_3 may be taken:

$$n_1 \geq 4; n_2 \geq 1 \text{ and } n_3 \leq 4,5 \text{ kN} \quad \text{or}$$

$$n_1 \geq 3; n_2 \geq 1 \text{ and } n_3 \leq 3,0 \text{ kN}.$$

Fitness for the intended use of the anchor is given under the following conditions:

- The design of anchorages is carried out in compliance with ETAG 020, Guideline for European Technical Approval of "Plastic Anchors for Multiple Use in Concrete and Masonry for Non-structural Applications", Annex C under the responsibility of an engineer experienced in anchorages. This design method applies to plastic anchors subject to static or quasi-static actions in tension, shear or combined tension and shear or bending; it is not applicable to plastic anchors loaded in compression or subject to fatigue, impact, or seismic actions.
- Verifiable calculation notes and drawings shall be prepared taking account of the loads to be anchored, the nature and strength of the base materials and the dimensions of the anchorage members as well as of the relevant tolerances.

Shear loads acting on an anchor may be assumed to act without lever arm if both of the following conditions are fulfilled:

- The fixture shall be made of metal and in the area of the anchorage be fixed directly to the base material either without an intermediate layer or with a leveling layer of mortar with a thickness ≤ 3 mm.
- The fixture shall be in contact with the anchor over its entire thickness. (Therefore the diameter of clearance hole in the fixture d_f has to be equal or smaller than the value given in Annex 3, Table 3.)

If these two conditions are not fulfilled the lever arm is calculated according to ETAG 020, Annex C. The characteristic bending moment is given in Annex 4, Table 4.

4.2.1.2 Resistance in concrete (use category "a")

The characteristic values of resistance of the anchor for use in concrete are given in Annex 4, Table 4 and Annex 5, Table 6. The design method is valid for cracked and non-cracked concrete.

According to the Technical Report TR 020 "Evaluation of anchorages in concrete concerning resistance to fire" it can be assumed that for fastening of facade systems the load bearing behavior of the Plastic anchor FM-X5 ϕ 10 has a sufficient resistance to fire at least 90 minutes (R90) if the admissible load $[F_{Rk}/(\gamma_M \times \gamma_F)]$ is $\leq 0,8$ kN (no permanent centric tension load).

4.2.1.3 Resistance in solid masonry (use category “b”)

The characteristic values of resistance of the anchor for use in solid masonry are given in Annex 4, Table 4 and in Annex 7. These values are independent of the load direction (tension, shear or combined tension and shear) and the mode of failure.

The characteristic resistances given in Annex 7 for use in solid masonry are only valid for the base material and the bricks according this table or larger brick sizes and larger compressive strength of the masonry unit.

If smaller brick sizes are present on the construction site or if the mortar strength is smaller than the required value, the characteristic resistance of the anchor may be determined by job site tests according to 4.2.3.

4.2.1.4 Resistance in hollow or perforated masonry (use category “c”)

The characteristic values of resistance of the anchor for use in hollow or perforated masonry are given in Annex 4, Table 4 and Annexes 8 to 14. These values are independent of the load direction (tension, shear or combined tension and shear) and the mode of failure and are valid for $h_{nom} = 70$ mm only.

The characteristic resistances given in Annex 4, Table 4 and Annex 8 to 14 are only valid for the bricks and blocks according this table regarding base material, size of the units, compressive strength and configuration of the voids.

The influence of larger embedment depths ($h_{nom} > 70$ mm) and/or different bricks and blocks (according Annex 8 to 14 regarding base material, size of the units, compressive strength and configuration of the voids) has to be detected by job site tests according to 4.2.3.

4.2.1.5 Resistance in autoclaved aerated concrete (use category “d”)

The characteristic values of resistance of the anchor for use in masonry made of autoclaved aerated (noncracked) concrete blocks (AAC) are given in Annex 16, Table 19.3. These values are independent of the load direction (tension, shear or combined tension and shear) and the mode of failure and are valid for $h_{nom} \geq 70$ mm only.

The anchor should not be used in water saturated aerated concrete.

4.2.1.6 Specific conditions for the design method in solid masonry, hollow or perforated masonry an AAC blocks

The mortar strength class of the masonry has to be M2,5 according to EN 998-2:2003 at minimum.

The characteristic resistance F_{Rk} for a single plastic anchor may also be taken for a group of two or four plastic anchors with a spacing equal or larger than the minimum spacing s_{min} .

The distance between single plastic anchors or a group of anchors should be $s \geq 250$ mm.

If the vertical joints of the wall are designed not to be filled with mortar then the design resistance N_{Rd} has to be limited to 2,0 kN to ensure that a pull-out of one brick out of the wall will be prevented. This limitation can be omitted if interlocking units are used for the wall or when the joints are designed to be filled with mortar.

If the joints of the masonry are not visible the characteristic resistance F_{Rk} has to be reduced with the factor $\alpha_j = 0,5$.

If the joints of the masonry are visible (e.g. unplastered wall) following has to be taken into account:

- The characteristic resistance F_{Rk} may be used only, if the wall is designed such that the joints are to be filled with mortar.
- If the wall is designed such that the joints are not to be filled with mortar then the characteristic resistance F_{Rk} may be used only, if the minimum edge distance c_{min} to the vertical joints is

observed. If this minimum edge distance c_{\min} can not be observed then the characteristic resistance F_{Rk} has to be reduced with the factor $\alpha_j = 0,5$.

4.2.1.7 Characteristic values, spacing and dimensions of anchorage member

The minimum spacing and dimensions of anchorage member according to Annex 6, Table 8 and Annex 15, Table 18 and Annex 17, Table 21 shall be observed depending on the base material.

4.2.1.7 Displacement behaviour

The displacements under tension and shear loading in concrete are given in Annex 6, Table 7, in masonry in Annex 15, Table 17 and in autoclaved aerated concrete in Annex 17, Table 20.

4.2.2 Installation of anchor

The fitness for use of the anchor can only be assumed if the following conditions of installation are met:

- Anchor installation carried out by appropriately qualified personnel under the supervision of the person responsible for technical matters on site.
- Use of the anchor only as supplied by the manufacturer without exchanging any component of the anchor.
- Anchor installation in accordance with the manufacturer's specifications and drawings using the tools indicated in this European Technical Approval:
- Checks before placing the anchor, to ensure that the characteristic values of the base material in which the anchor is to be placed, is identical with the values, which the characteristic loads apply for.
- Observation of the drill method according Annex 8 to 14 (Drill holes in hollow or perforated masonry may only be drilled using the rotary drill. Other drilling methods may also be used if job-site tests according to 4.2.3 evaluate the influence of hammer or impact drilling.)
- Placing drill holes without damaging the reinforcement.
- Holes to be cleaned of drilling dust.
- In case of aborted hole: New drilling at a minimum distance away of twice the depth of the aborted hole or smaller distance if the aborted drill hole is filled with high strength mortar.
- The plastic sleeve is inserted through the fixture by slight hammer blows and the special screw is screwed in until the head of the screw touches the sleeve. The anchor is correct mounted, if there is no turn-through of the plastic sleeve in the drill hole and if slightly move on turning of the screw is impossible after the complete turn-in of the screw.
- Temperature during installation of the anchor ≥ -20 °C (plastic sleeve and base material).

4.2.3 Job site tests according to ETAG 020, Annex B

4.2.3.1 General

In the absence of national requirements the characteristic resistance of the plastic anchor may be determined by job site tests, if the plastic anchor has already characteristic values given in Annex 8 to 14 for the same base material as it is present on the construction works.

Furthermore job site tests for use in (different) solid masonry are possible only if the plastic anchor has already characteristic values given in Annex 8 for use in solid masonry.

Job site tests for use in (different) hollow or perforated masonry are possible only if the plastic anchor has already characteristic values given in Annex 9 to 14 for use in hollow or perforated masonry.

Job site tests are also possible, if another drill method is been used as it is given in Annex 9 to 14.

The characteristic resistance to be applied to a plastic anchor should be determined by means of at least 15 pull-out tests carried out on the construction work with a centric tension load acting on the plastic anchor. These tests may also be performed in a laboratory under equivalent conditions as used on construction work.

Execution and evaluation of the tests as well as issue of the test report and determination of the characteristic resistance should be supervised by the person responsible for execution of works on site and be carried out by a competent person.

Number and position of the plastic anchors to be tested should be adapted to the relevant special conditions of the construction work in question and, for example, in the case of blind and larger areas be increased such that a reliable information about the characteristic resistance of the plastic anchor embedded in the base material in question can be derived. The tests should take account of the unfavorable conditions of practical execution.

4.2.3.2 Assembly

The plastic anchor to be tested shall be installed (e.g. preparation of drill hole, drilling tool to be used, drill bit, type of drilling hammer or rotation, thickness of fixture) and as far as spacing and edge distances are concerned be distributed in the same way as foreseen for the intended use.

Depending on the drilling tool hard metal hammer drill bits or hard metal percussion drill bits, respectively, according to ISO 5468 should be used. New drill bits should be used for one test series or drill bits with $d_{\text{cut,m}} = 10,25 \text{ mm} < d_{\text{cut}} \leq 10,45 \text{ mm} = d_{\text{cut,max}}$ for anchors FM-X5 10 and $d_{\text{cut,m}} = 8,25 \text{ mm} < d_{\text{cut}} \leq 8,45 \text{ mm} = d_{\text{cut,max}}$ for anchors FM-X5 8.

4.2.3.3 Execution of test

The test rig used for the pull-out tests shall provide a continuous slow increase of the load, controlled by a calibrated load cell. The load shall apply perpendicular to the surface of the base material and shall be transmitted to the anchor via a hinge. The reaction forces shall be transmitted into the base material such that possible breakout of the masonry is not restricted. This condition is considered as fulfilled, if the support reaction forces are transmitted either in adjacent masonry units or at a distance of at least 150 mm from the plastic anchors. The load shall be increased continuously in a way that the ultimate load is reached after about 1 minute. The load is measured when the ultimate load (N_1) is achieved. If no pull-out failure occurs, other test methods are needed, e.g. proof-loading.

4.2.3.4 Test report

The test report shall include all information necessary to assess the resistance of the tested anchor. It shall be given to the person responsible for the design of the fastening and shall be included in the construction dossier.

The minimum data required are:

- Name of product;
- Construction site, owner of building; date and location of the tests, air temperature;
- Date and place of tests;
- Test rig;
- Type of structure to be fixed;
- Masonry (type of brick, strength class, all dimensions of bricks, mortar group if possible); visual assessment of masonry (flush joints, joint clearance, regularity);
- Plastic anchor and special screw; value of the cutting diameter of hard metal hammer-drill bits, measured before and after drilling if no new drill bits are used;
- Results of tests including the indication of value N_1 ; mode of failure;
- Tests carried out or supervised by ...; signature.

4.2.3.5 Evaluation of test results

The characteristic resistance F_{Rk1} is derived from the measured values N_1 as follows

$$F_{Rk1} = 0,5 \times N_1$$

The characteristic resistance F_{Rk1} has to be equal or smaller than the characteristic resistance F_{Rk} which is given in the ETA for similar masonry (bricks or blocks)

$$N_1 = \text{the mean value of the five smallest measured values at ultimate load}$$

In absence of national regulations the partial safety factors for the resistance of the plastic anchor may be taken as $\gamma_{Mm} = 2,5$ for use in masonry.

4.2.4 Responsibility for the manufacturer

It is in the responsibility of the manufacturer to ensure that the information on the specific conditions according to 1 and 2 including Annexes referred to 4.2.1, 4.2.2 and 5 is given to those who are concerned. This information may be made by reproduction of the respective parts of the European Technical Approval. In addition, all installation data shall be shown clearly on the packaging and/or on an enclosed instruction sheet, preferably using illustration.

The minimum data required are:

- base material for the intended use,
- ambient temperature of base material during installation of anchor,
- drill bit diameter,
- minimum effective anchorage depth,
- minimum hole depth,
- information on the installation procedure,
- identification of the manufacturing batch.

All data shall be presented in a clear and explicit form.

5 Indications to the manufacturer

5.1 Packing, transport and storage

The anchor shall only be supplied as a complete unit.

The anchor shall be stored under normal climatic conditions in its original light-proof packaging. Before installation, it shall not be extremely dried or frozen.

Leading expert:

Dušica Drobnič, M.Sc., (Civ.eng.)

Head of the Service for Technical Approvals:

Franc Capuder, M.Sc., (Civ.eng.)

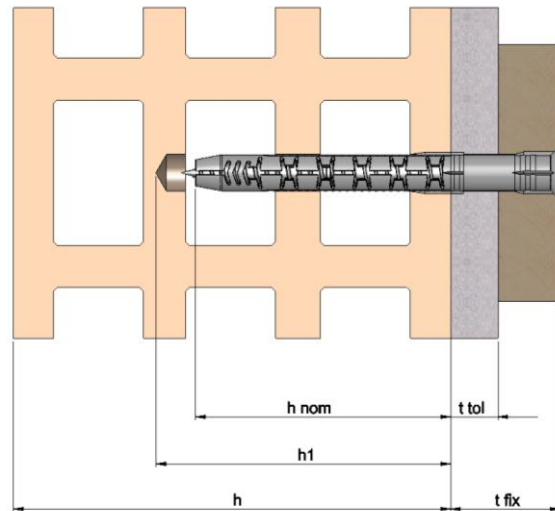
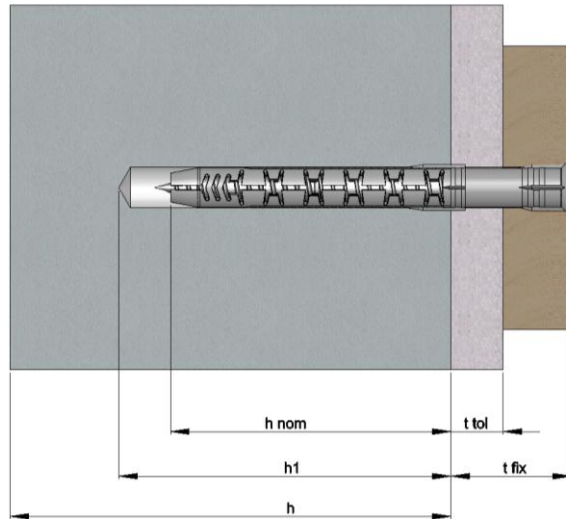

- h_1 = depth of drill hole to deepest point
- h_{nom} = overall plastic anchor embedment depth in base material
- h = thickness of member
- t_{tol} = thickness of non-structural layer
- t_{fix} = thickness of fixture

FM-X5

Intended use

Annex 1

of the European Technical Approval

ETA-10/0425

Plastic sleeve

Sleeve with countersunk head

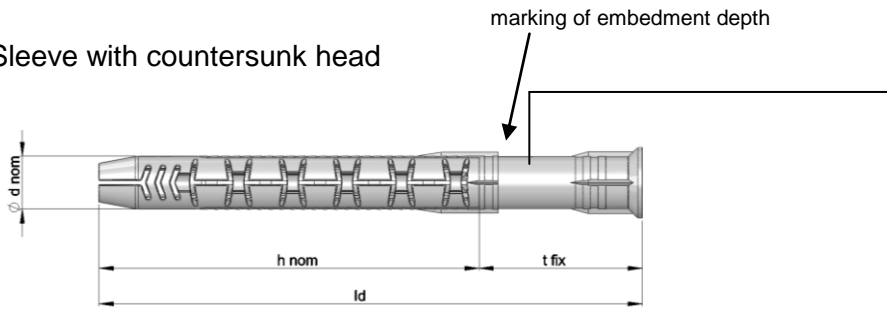

Sleeve with collar head

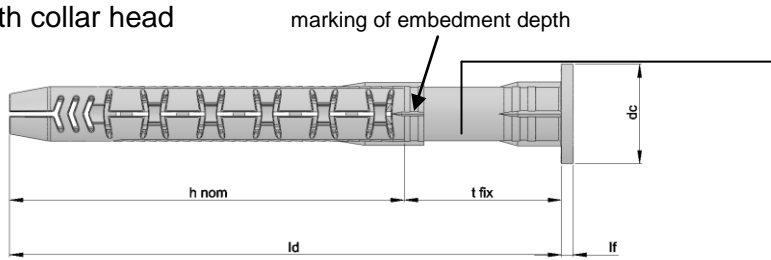

Marking:

- Identifying mark of the producer
- Anchor type
- Diameter/length
- Maximum thickness of the fixture

e.g.

X5 ϕ 10 \times 100 \Leftarrow 30 \Rightarrow .

Special screw

Screw with countersunk head (used for both versions of a sleeve)

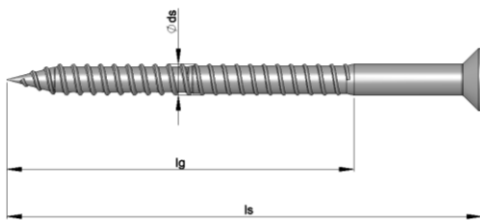

head of screw for galvanised steel and stainless steel A4



head of screw for stainless steel A4-70



Screw with hexagonal head (used for both versions of a sleeve)

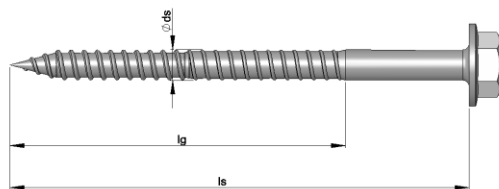

head of screw for galvanised steel and stainless steel A4



head of screw for stainless steel A4-70



FM-X5

Sleeve and special screw

Annex 2

of the European Technical Approval

ETA-10/0425

Table 1: Anchor dimensions

Anchor type			FM-X5 8	FM-X5 10
Overall plastic anchor embedment depth	$h_{nom} \geq$	[mm]	70	70
Plastic sleeve				
Plastic sleeve diameter	d_{nom}	[mm]	8	10
Length of plastic sleeve	l_d	[mm]	80-170	85-270
Diameter of collar head	d_c	[mm]	-	18
Thickness of collar head	l_f	[mm]	-	2,2
Thickness of fixture	t_{fix}	[mm]	1-100	1-200
Special screw				
Screw diameter	d_s	[mm]	6	7
Length of screw	l_s	[mm]	85-175	90-275
Minimum length of thread	l_g	[mm]	75	75

Table 2: Materials

Part	Material
Anchor sleeve	Polyamide PA 6 acc. To ISO 1874 - grey color
Special screw	<p>steel ϕ 7; galvanized 5μm acc. to EN ISO 4042 grey galvanic coating 10 μm acc. to EN ISO 4042; $f_{uk} \geq 600$ MPa, $f_{yk} \geq 480$ MPa stainless A4 – 1.4401 or 1.4404 or 1.4571 or 1.4578, $f_{uk} \geq 580$ MPa, $f_{yk} \geq 470$ MPa stainless A4-70 – 1.4401 or 1.4404 or 1.4571 or 1.4578, $f_{uk} \geq 700$ MPa, $f_{yk} \geq 450$ MPa steel ϕ 6; galvanized 5μm acc. to EN ISO 4042 grey galvanic coating 10 μm acc. to EN ISO 4042; $f_{uk} \geq 520$ MPa, $f_{yk} \geq 420$ MPa stainless A4 – 1.4401 or 1.4404 or 1.4571 or 1.4578, $f_{uk} \geq 580$ MPa, $f_{yk} \geq 470$ MPa stainless A4-70 – 1.4401 or 1.4404 or 1.4571 or 1.4578, $f_{uk} \geq 700$ MPa, $f_{yk} \geq 450$ MPa</p>

Table 3: Installation parameters

Anchor type			FM-X5 8	FM-X5 10
Drill hole diameter	$d_0 =$	[mm]	8	10
Cutting diameter of drill bit	$d_{cut} \leq$	[mm]	8,45	10,45
Depth of frill hole to deepest point	$h_1 \geq$	[mm]	80	80
Overall plastic anchor embedment depth ¹⁾	h_{nom}	[mm]	70	70
Diameter of clearance hole in the fixture	d_f	[mm]	8,5	10,5

¹⁾ See Annex 1

FM-X5	Annex 3 of the European Technical Approval ETA-10/0425
Dimensions, materials and installation data	

Table 4: Characteristic bending resistance of the special screw in concrete, masonry and autoclaved aerated concrete

		Galvanized steel		Stainless steel A4		Stainless steel A4-70	
		FM-X5 8	FM-X5 10	FM-X5 8	FM-X5 10	FM-X5 8	FM-X5 10
Characteristic bending resistance	$M_{Rk,s}$ [Nm]	8,61	16,84	9,60	21,95	13,57	24,78
Partial safety factor	γ_{Ms} ¹⁾	1,23	1,25	1,25	1,25	1,56	1,56

¹⁾ In absence of other national regulations

Table 5: Base material

Base material	Dimensions L×B×H [mm]	Minimum compressive strength [MPa]	Bulk density class [kg/dm ³]	Annex
Concrete				
Concrete ≥ C12/15	EN 206-1			Annex 5
Solid masonry				
Solid brick acc. to EN 771-1	251×120×55	43,77	≥ 1,8	Annex 7
Hollow or perforated masonry				
Hollow clay brick – bimattone acc. to EN 771-1	250×120×120	27,30	≥ 1,0	Annex 8
Hollow clay brick – alveolater svizzero pesante acc. to EN 771-1	300×250×190	13,83	≥ 0,9	Annex 9
Hollow clay brick – alveolater incastro35 acc.to EN 771-1	350×240×245	10,93	≥ 0,8	Annex 10
Hollow clay brick – blocco leggero acc. to EN 771-1	250×120 500	7	≥ 0,5	Annex 11
Hollow clay brick – poroton acc.to EN 771-1	250×300×190	22	≥ 0,9	Annex 12
Hollow clay brick – BP category 1 – HD acc.to EN 771-1	224×106×54	30	≥ 1,3	Annex 13
Hollow brick light weight concrete BC 203 n°26 acc.to EN 771-3	490×200×190	4	≥ 0,95	Annex 14
Autoclaved aerated concrete – AAC gasbeton evolution 500	625×250×200	2,5	≥ 0,50	Annex 16

FM-X5**Annex 4**

Characteristic bending resistance
Base material

of the European Technical
Approval

ETA-10/0425

Table 6: Characteristic resistance for use in concrete

Anchor type			FM-X5 8			FM-X5 10		
Failure of expansion element (special screw)			Galvan. steel	Stainless steel		Galvan. steel	Stainless steel	
				A4	A4-70		A4	A4-70
Characteristic tension resistance	$N_{Rk,s}$	[kN]	11,0	12,3	16,5	18,1	21,2	25,0
Partial safety factor	$\gamma_{Ms}^{1)}$	[-]	1,48	1,48	1,88	1,50	1,48	1,88
Characteristic shear resistance	$V_{Rk,s}$	[kN]	5,52	6,16	8,25	9,05	10,60	12,5
Partial safety factor	$\gamma_{Ms}^{1)}$	[-]	1,23	1,23	1,56	1,25	1,25	1,56
Pull-out failure (plastic sleeve)								
Concrete \geq C16/20								
Characteristic resistance	$24^{\circ}\text{C}^2)/40^{\circ}\text{C}^3)$	$N_{Rk,p}$	[kN]	2,5			3,5	
	$50^{\circ}\text{C}^2)/80^{\circ}\text{C}^3)$	$N_{Rk,p}$	[kN]	1,2			2,5	
Partial safety factor	$\gamma_{Mc}^{1)}$	[-]	1,8					
Concrete C12/15								
Characteristic resistance	$24^{\circ}\text{C}^2)/40^{\circ}\text{C}^3)$	$N_{Rk,p}$	[kN]	1,5			2,5	
	$50^{\circ}\text{C}^2)/80^{\circ}\text{C}^3)$	$N_{Rk,p}$	[kN]	0,75			1,5	
Partial safety factor	$\gamma_{Mc}^{1)}$	[-]	1,8					
Concrete cone failure and concrete edge failure for single anchor and anchor group								
Tension load ⁴⁾								
$N_{Rk,c} = 7,2 \cdot \sqrt{f_{ck,cube}} \cdot h_{ef}^{1,5} \cdot \frac{c}{c_{cr,N}} = N_{Rk,p} \cdot \frac{c}{c_{cr,N}}$			with: $h_{ef} = \frac{N_{Rk,p}}{7,2 \cdot \sqrt{f_{ck,cube}}}$					
			$\frac{c}{c_{cr,N}} \leq 1$					
Shear load ⁴⁾								
$V_{Rk,c} = 0,45 \sqrt{d_{nom}} \cdot \left(\frac{h_{nom}}{d_{nom}}\right)^{0,2} \cdot \sqrt{f_{ck,cube}} \times c_1^{1,5} \times 0,5 \times \sqrt{\frac{c_2}{1,5c_1}} \cdot \sqrt{\frac{h}{1,5c_1}}$			with: $\sqrt{\frac{c_2}{1,5c_1}} \leq 1$					
			$\sqrt{\frac{h}{1,5c_1}} \leq 1$					
c_1	edge distance closest to the edge in loading direction							
c_2	edge distance perpendicular to direction 1							
$f_{ck,cube}$	nominal characteristic concrete compression strength (based on cubes), values for C50/60 at maximum							
Partial safety factor	$\gamma_{Mc}^{1)}$	[-]	1,8					

1) In absence of other national regulations

2) Maximum long term temperature

3) Maximum short term temperature

4) The design method according to ETAG 020, Annex C is to be used

FM-X5

Characteristic resistance for use in concrete

Annex 5

of the European Technical Approval

ETA-10/0425

Table 7: Displacements under tension and shear loading in concrete

Concrete \geq C 16/20	Tension load			Shear load		
	F	δ_{N0}	$\delta_{N\infty}$	F	δ_{V0}	$\delta_{V\infty}$
	[kN]	[mm]	[mm]	[kN]	[mm]	[mm]
FM-X5 8	1,0	3,76	7,52	1,0	1,60	2,40
FM-X5 10	1,4	1,79	3,58	1,4	0,90	1,35

Table 8: Minimum thickness of member, edge distance and anchor spacing in concrete

FM-X5			Concrete C12/15	Concrete \geq 16/20
Minimum thickness of member	h_{min}	[mm]	100	100
Minimum spacing and edge distance	c_{min}	[mm]	80	60
	s_{min}	[mm]	80	60
Characteristic edge distance	$c_{cr,N}$	[mm]	140	100

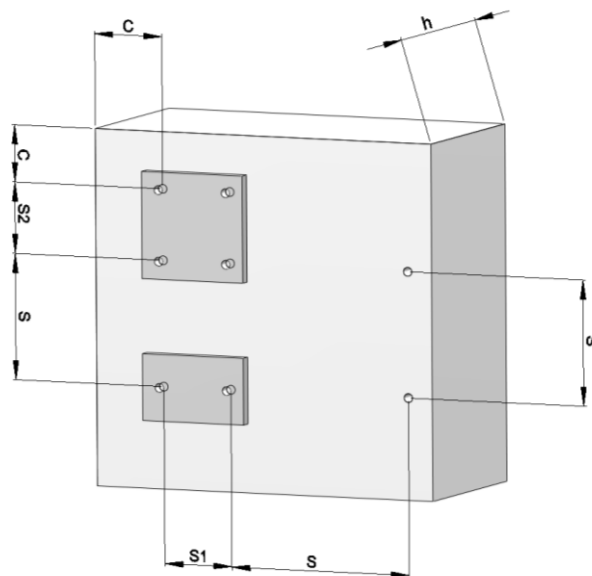

FM-X5

Displacements
Minimum thickness of member, edge distance and anchor spacing in concrete

Annex 6

of the European Technical Approval

ETA-10/0425

Base material solid masonry: Solid brick**Table 9.1: Brick data**

Description of brick			
Type of brick			Solid brick
Bulk density	$\rho \geq$	[kg/dm ³]	1,8
Standard			EN 771-1
Format (measurement)		[mm]	$\geq 250/120/55$
Minimum thickness of member	h_{\min}	[mm]	120

Table 9.2: Installation parameters

Anchor size			FM-X5 8	FM-X5 10
Drill hole diameter	$d_0 =$	[mm]	8	10
Cutting diameter of drill bit	$d_{\text{cut}} \leq$	[mm]	8,45	10,45
Depth of drill hole to deepest point	$h_1 \geq$	[mm]	80	
Drill method		[-]	Hammer drilling	
Overall plastic embedment depth	$h_{\text{nom}} =$	[mm]	70	
Diameter of clearance hole in the fixture	d_f	[mm]	8,5	10,5

Table 9.3: Characteristic resistance F_{Rk} ¹⁾ for single anchor

Anchor size			FM-X5 8	FM-X5 10
Solid clay brick $f_b \geq 43,77$ MPa	$24^\circ\text{C}^3/40^\circ\text{C}^4$	[kN]	3,5	3,5
	$50^\circ\text{C}^3/80^\circ\text{C}^4$	[kN]	2,0	2,5
Characteristic resistance F_{Rk}				
Partial safety factor	γ_{Mm} ²⁾	[-]	2,5	

¹⁾ Characteristic resistance F_{Rk} for tension, shear or combined tension and shear loading. The characteristic resistance is valid for single plastic anchor or for group of two or four plastic anchors with a spacing equal or larger than the minimum spacing s_{\min} according to Table 18. The specific conditions for the design method have to be considered according to chapter 4.2.1.5 of the ETA.

²⁾ IN absence of other national regulations

³⁾ Maximum long term temperature

⁴⁾ Maximum short term temperature

FM-X5**Solid masonry: Solid brick**

Brick data, installation parameters, characteristic resistance

Annex 7

of the European Technical Approval

ETA-10/0425

Base material hollow masonry: Hollow clay brick - Bimattone**Table 10.1: Brick data**

Description of brick		
Type of brick		Hollow clay brick - Bimattone
Bulk density	$\rho \geq$ [kg/dm ³]	0,9
Standard		EN 771-1
Producer of brick		Fornaci Giuliane S.p.a 34071 Cormons (Go) Italy
Format (measurement)	[mm]	$\geq 250/120/120$
Minimum thickness of member	h_{min} [mm]	120

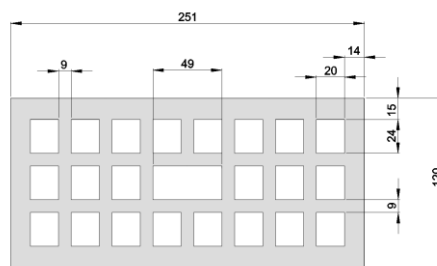
**Table 10.2: Installation parameters**

Anchor size		FM-X5 8	FM-X5 10
Drill hole diameter	$d_0 =$ [mm]	8	10
Cutting diameter of drill bit	$d_{cut} \leq$ [mm]	8,45	10,45
Depth of drill hole to deepest point	$h_1 \geq$ [mm]	80	
Drill method	[-]	Rotary drilling	
Overall plastic embedment depth	$h_{nom} =$ [mm]	70	
Diameter of clearance hole in the fixture	d_f [mm]	8,5	10,5

Table 10.3: Characteristic resistance F_{Rk} ¹⁾ for single anchor

Anchor size		FM-X5 8	FM-X5 10
Hollow brick - Bimattone $f_b \geq 27,3$ MPa	$24^\circ\text{C}^{3)/40^\circ\text{C}^{4)}$ [kN]	1,5	1,5
Characteristic resistance F_{Rk}	$50^\circ\text{C}^{3)/80^\circ\text{C}^{4)}$ [kN]	0,9	1,2
Partial safety factor	$\gamma_{Mm}^{2)}$ [-]	2,5	

¹⁾ Characteristic resistance F_{Rk} for tension, shear or combined tension and shear loading. The characteristic resistance is valid for single plastic anchor or for group of two or four plastic anchors with a spacing equal or larger than the minimum spacing s_{min} according to Table 18. The specific conditions for the design method have to be considered according to chapter 4.2.1.5 of the ETA.

²⁾ IN absence of other national regulations

³⁾ Maximum long term temperature

⁴⁾ Maximum short term temperature

FM-X5

Hollow masonry: Hollow clay brick Bimattone
Brick data, installation parameters, characteristic resistance

Annex 8

of the European Technical Approval

ETA-10/0425

Base material hollow masonry: Hollow clay brick - Alveolater svizzero pesante

Table 11.1: Brick data

Description of brick		
Type of brick		Hollow clay brick Alveolater svizzero pesante
Bulk density	$\rho \geq$	[kg/dm ³] 0,9
Standard		EN 771-1
Producer of brick		Fornaci Giuliane S.p.a 34071 Cormons (Go) Italy
Format (measurement)		[mm] $\geq 300/250/190$
Minimum thickness of member	h_{min}	[mm] 250

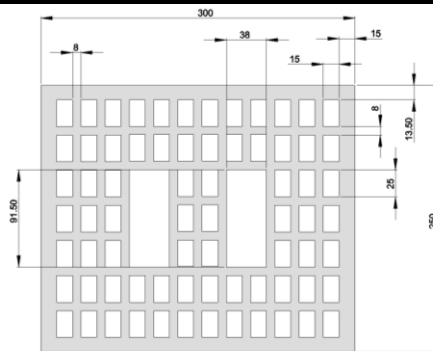

Table 11.2: Installation parameters

Anchor size		FM-X5 8	FM-X5 10
Drill hole diameter	$d_0 =$	[mm] 8	10
Cutting diameter of drill bit	$d_{cut} \leq$	[mm] 8,45	10,45
Depth of drill hole to deepest point	$h_1 \geq$	[mm] 80	
Drill method		[-] Rotary drilling	
Overall plastic embedment depth	$h_{nom} =$	[mm] 70	
Diameter of clearance hole in the fixture	d_f	[mm] 8,5	10,5

Table 11.3: Characteristic resistance F_{Rk} ¹⁾ for single anchor

Anchor size		FM-X5 8	FM-X5 10
Hollow brick - Alveolater svizzero pesante $f_b \geq 13,83$ MPa	$24^\circ\text{C}^3/40^\circ\text{C}^4$	[kN] 1,5	1,5
	$50^\circ\text{C}^3/80^\circ\text{C}^4$	[kN] 0,6	1,2
Characteristic resistance F_{Rk}			
Partial safety factor	γ_{Mm} ²⁾	[-] 2,5	

¹⁾ Characteristic resistance F_{Rk} for tension, shear or combined tension and shear loading. The characteristic resistance is valid for single plastic anchor or for group of two or four plastic anchors with a spacing equal or larger than the minimum spacing s_{min} according to Table 18. The specific conditions for the design method have to be considered according to chapter 4.2.1.5 of the ETA.

²⁾ IN absence of other national regulations

³⁾ Maximum long term temperature

⁴⁾ Maximum short term temperature

FM-X5	Annex 9 of the European Technical Approval ETA-10/0425
Hollow masonry: Hollow clay brick - Alveolater svizzero pesante Brick data, installation parameters, characteristic resistance	

Base material hollow masonry: Hollow clay brick - Alveolater incastro 35

Table 12.1: Brick data

Description of brick		
Type of brick		Hollow clay brick Alveolater incastro 35
Bulk density	$\rho \geq$	[kg/dm ³] 0,8
Standard		EN 771-1
Producer of brick		Fornaci Giuliane S.p.a 34071 Cormons (Go) Italy
Format (measurement)		[mm] $\geq 350/240/245$
Minimum thickness of member	h_{min}	[mm] 350

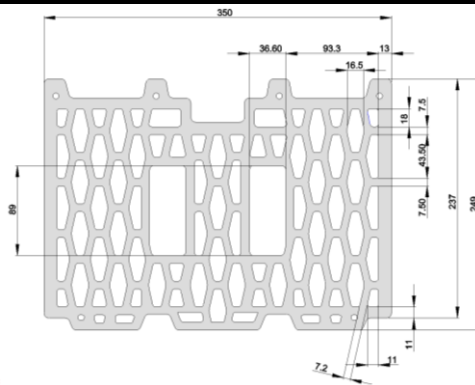

Table 12.2: Installation parameters

Anchor size		FM-X5 8	FM-X5 10
Drill hole diameter	$d_0 =$	[mm] 8	10
Cutting diameter of drill bit	$d_{cut} \leq$	[mm] 8,45	10,45
Depth of drill hole to deepest point	$h_1 \geq$	[mm] 80	
Drill method		[-] Rotary drilling	
Overall plastic embedment depth	$h_{nom} =$	[mm] 70	
Diameter of clearance hole in the fixture	d_f	[mm] 8,5	10,5

Table 12.3: Characteristic resistance F_{Rk} ¹⁾ for single anchor

Anchor size		FM-X5 8	FM-X5 10
Hollow brick - Alveolater incastro 35	$24^\circ\text{C}^3/40^\circ\text{C}^4$	[kN] 1,5	1,5
$f_b \geq 10,93$ MPa	$50^\circ\text{C}^3/80^\circ\text{C}^4$	[kN] 0,75	1,2
Characteristic resistance F_{Rk}			
Partial safety factor	$\gamma_{Mm}^2)$	[-] 2,5	

¹⁾ Characteristic resistance F_{Rk} for tension, shear or combined tension and shear loading. The characteristic resistance is valid for single plastic anchor or for group of two or four plastic anchors with a spacing equal or larger than the minimum spacing s_{min} according to Table 18. The specific conditions for the design method have to be considered according to chapter 4.2.1.5 of the ETA.

²⁾ IN absence of other national regulations

³⁾ Maximum long term temperature

⁴⁾ Maximum short term temperature

FM-X5	Annex 10 of the European Technical Approval ETA-10/0425
Hollow masonry: Hollow clay brick - Alveolater incastro 35 Brick data, installation parameters, characteristic resistance	

Base material hollow masonry: Hollow clay brick - Blocco leggero

Table 13.1: Brick data

Description of brick		
Type of brick		Hollow clay brick Blocco leggero
Bulk density	$\rho \geq$	[kg/dm ³] 0,5
Standard		EN 771-1
Producer of brick		Wienerberger Brunori SRL Burbano di Modano (Bo) Italy
Format (measurement)		[mm] $\geq 250/120/500$
Minimum thickness of member	h_{min}	[mm] 120

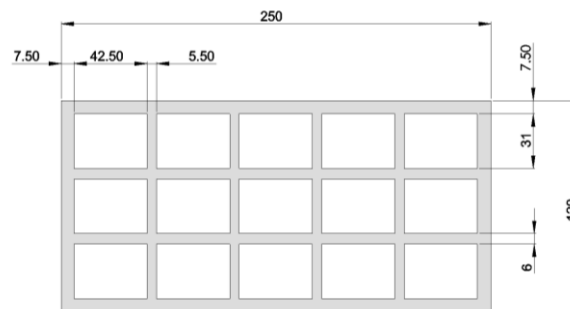

Table 13.2: Installation parameters

Anchor size		FM-X5 8	FM-X5 10
Drill hole diameter	$d_0 =$	[mm] 8	10
Cutting diameter of drill bit	$d_{cut} \leq$	[mm] 8,45	10,45
Depth of drill hole to deepest point	$h_1 \geq$	[mm] 80	
Drill method		[-] Rotary drilling	
Overall plastic embedment depth	$h_{nom} =$	[mm] 70	
Diameter of clearance hole in the fixture	d_f	[mm] 8,5	10,5

Table 13.3: Characteristic resistance F_{Rk} ¹⁾ for single anchor

Anchor size		FM-X5 8	FM-X5 10
Hollow brick - Blocco leggero $f_b \geq 7$ MPa	$24^\circ\text{C}^3/40^\circ\text{C}^4$	[kN] 0,9	0,9
	$50^\circ\text{C}^3/80^\circ\text{C}^4$	[kN] 0,4	0,6
Partial safety factor	$\gamma_{Mm}^2)$	[-] 2,5	

¹⁾ Characteristic resistance F_{Rk} for tension, shear or combined tension and shear loading. The characteristic resistance is valid for single plastic anchor or for group of two or four plastic anchors with a spacing equal or larger than the minimum spacing s_{min} according to Table 18. The specific conditions for the design method have to be considered according to chapter 4.2.1.5 of the ETA.

²⁾ IN absence of other national regulations

³⁾ Maximum long term temperature

⁴⁾ Maximum short term temperature

FM-X5	Annex 11 of the European Technical Approval ETA-10/0425
Hollow masonry: Hollow clay brick - Blocco leggero Brick data, installation parameters, characteristic resistance	

Base material hollow masonry: Hollow clay brick - Poroton**Table 14.1: Brick data**

Description of brick		
Type of brick		Hollow clay brick - Poroton
Bulk density	$\rho \geq$	[kg/dm ³] 0,9
Standard		EN 771-1
Producer of brick		Fornaci di Manzano S.p.a 33044 Manzano (Ud) Italy
Format (measurement)		[mm] $\geq 250/300/190$
Minimum thickness of member	h_{min}	[mm] 250

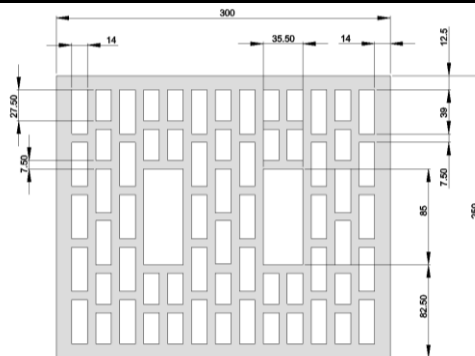
**Table 14.2: Installation parameters**

Anchor size		FM-X5 8	FM-X5 10
Drill hole diameter	d_0	[mm] 8	10
Cutting diameter of drill bit	$d_{cut} \leq$	[mm] 8,45	10,45
Depth of drill hole to deepest point	$h_1 \geq$	[mm] 80	
Drill method		[-] Rotary drilling	
Overall plastic embedment depth	$h_{nom} =$	[mm] 70	
Diameter of clearance hole in the fixture	d_f	[mm] 8,5	10,5

Table 14.3: Characteristic resistance F_{Rk} ¹⁾ for single anchor

Anchor size		FM-X5 8	FM-X5 10
Hollow brick - Poroton $f_b \geq 22$ MPa	$24^\circ\text{C}^3/40^\circ\text{C}^4$	[kN] 1,5	2,0
	$50^\circ\text{C}^3/80^\circ\text{C}^4$	[kN] 0,9	1,2
Partial safety factor	γ_{Mm}^2	[-] 2,5	

¹⁾ Characteristic resistance F_{Rk} for tension, shear or combined tension and shear loading. The characteristic resistance is valid for single plastic anchor or for group of two or four plastic anchors with a spacing equal or larger than the minimum spacing s_{min} according to Table 18. The specific conditions for the design method have to be considered according to chapter 4.2.1.5 of the ETA.

²⁾ IN absence of other national regulations

³⁾ Maximum long term temperature

⁴⁾ Maximum short term temperature

FM-X5

Hollow masonry: Hollow clay brick - Poroton
Brick data, installation parameters, characteristic resistance

Annex 12

of the European Technical Approval

ETA-10/0425

Base material hollow masonry: Hollow clay brick Leopard Brique Perforée category 1-HD**Table 15.1: Brick data**

Description of brick		
Type of brick		Hollow clay brick - Leopard BP category 1-HD
Bulk density	$\rho \geq$	[kg/m ³] 1,3
Standard		EN 771-1
Producer of brick		Pacema Groupe Wienerberge F- 67087 Strasbourg
Format (measurement)		[mm] $\geq 220/106/54$
Minimum thickness of member	h_{\min}	[mm] 106

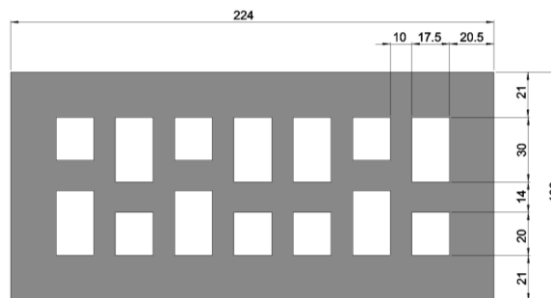
**Table 15.2: Installation parameters**

Anchor size		FM-X5 8	FM-X5 10
Drill hole diameter	d_0	[mm] 8	10
Cutting diameter of drill bit	$d_{\text{cut}} \leq$	[mm] 8,45	10,45
Depth of drill hole to deepest point	$h_1 \geq$	[mm] 80	
Drill method		[-] Rotary drilling	
Overall plastic embedment depth	$h_{\text{nom}} =$	[mm] 70	
Diameter of clearance hole in the fixture	d_f	[mm] 8,5	10,5

Table 15.3: Characteristic resistance F_{Rk} ¹⁾ for single anchor

Anchor size		FM-X5 8	FM-X5 10
Hollow clay brick - Leopard BP category 1HD $f_b \geq 30 \text{ MPa}$	$24^\circ\text{C}^3/40^\circ\text{C}^4$	[kN] 2,0	1,5
	$50^\circ\text{C}^3/80^\circ\text{C}^4$	[kN] 0,9	0,9
Characteristic resistance F_{Rk}			
Partial safety factor	$\gamma_{Mm}^2)$	[-] 2,5	

¹⁾ Characteristic resistance F_{Rk} for tension, shear or combined tension and shear loading. The characteristic resistance is valid for single plastic anchor or for group of two or four plastic anchors with a spacing equal or larger than the minimum spacing s_{\min} according to Table 18. The specific conditions for the design method have to be considered according to chapter 4.2.1.5 of the ETA.

²⁾ IN absence of other national regulations

³⁾ Maximum long term temperature

⁴⁾ Maximum short term temperature

FM-X5**Annex 13**

**Hollow masonry: Hollow clay brick -
Leopard BP category 1-HD**
Brick data, installation parameters, characteristic
resistance

of the European Technical
Approval

ETA-10/0425

Base material hollow masonry: Blocks creux granulate en beton allege**Table 16.1: Brick data**

Description of brick			
Type of brick			Hollow brick light weight concrete BC 203 n°26
Bulk density	$\rho \geq$	[kg/dm ³]	0,95
Standard			EN 771-3
Producer of brick			Carayon F-11590 Salleled d'Aude
Format (measurement)		[mm]	$\geq 490/200/190$
Minimum thickness of member	h_{\min}	[mm]	200

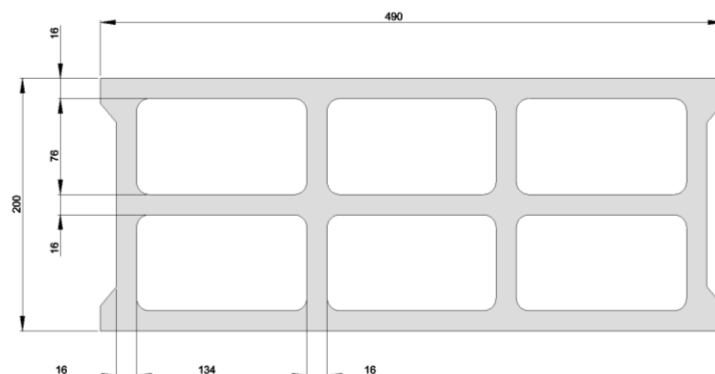
**Table 16.2: Installation parameters**

Anchor size			FM-X5 8	FM-X5 10
Drill hole diameter	d_0	[mm]	8	10
Cutting diameter of drill bit	$d_{\text{cut}} \leq$	[mm]	8,45	10,45
Depth of drill hole to deepest point	$h_1 \geq$	[mm]	80	
Drill method		[-]	Rotary drilling	
Overall plastic embedment depth	$h_{\text{nom}} =$	[mm]	70	
Diameter of clearance hole in the fixture	d_f	[mm]	8,5	10,5

Table 16.3: Characteristic resistance F_{Rk} ¹⁾ for single anchor

Anchor size			FM-X5 8	FM-X5 10
Hollow brick BC 203 n°26	$f_b \geq 4 \text{ MPa}$	$24^\circ\text{C}^3/40^\circ\text{C}^4$	[kN]	0,75
Characteristic resistance F_{Rk}		$50^\circ\text{C}^3/80^\circ\text{C}^4$	[kN]	0,3
Partial safety factor	γ_{Mm}^2	[-]	2,5	

¹⁾ Characteristic resistance F_{Rk} for tension, shear or combined tension and shear loading. The characteristic resistance is valid for single plastic anchor or for group of two or four plastic anchors with a spacing equal or larger than the minimum spacing s_{\min} according to Table 18. The specific conditions for the design method have to be considered according to chapter 4.2.1.5 of the ETA.

²⁾ In absence of other national regulations

³⁾ Maximum long term temperature

⁴⁾ Maximum short term temperature

FM-X5**Annex 14**

Hollow masonry: Blocks creux granulate en beton allege
Brick data, installation parameters, characteristic resistance

of the European Technical Approval

ETA-10/0425

Table 17: Displacements under tension and shear loading in masonry

Base material	F	Displacement				F	Displacement			
		Tension load		Shear load			Tension load		Shear load	
		δ_{N0}	$\delta_{N\infty}$	δ_{V0}	$\delta_{V\infty}$		$\delta_{V\infty}$	$\delta_{V\infty}$	$\delta_{V\infty}$	$\delta_{V\infty}$
	[kN]	[mm]	[mm]	[mm]	[mm]	[mm]	[mm]	[mm]		
	FM-X5 8					FM-X5 10				
Solid clay brick	1,00	1,55	3,00	0,83	1,25	1,00	2,40	4,80	0,83	1,25
Hollow clay brick - bimattone	0,43	1,81	3,62	0,86	1,29	0,43	1,70	3,40	0,86	1,29
Hollow clay brick – alveolater svizzero pesante	0,43	1,00	2,00	0,86	1,29	0,43	0,89	1,78	0,86	1,29
Hollow clay brick – alveolater 35	0,43	1,51	3,02	0,86	1,29	0,43	1,65	3,30	0,86	1,29
Hollow clay brick – blocco leggero	0,26	1,71	3,42	0,52	0,78	0,26	1,05	2,10	0,52	0,78
Hollow clay brick – poroton	0,43	1,80	3,60	0,86	1,29	0,57	1,61	3,22	0,86	1,29
Hollow clay brick – BP category 1 - HD	0,57	0,83	1,66	1,14	1,71	0,43	0,95	1,90	1,14	1,71
Hollow brick – light weight concrete – BC 203	0,21	2,32	4,64	1,00	1,50	0,17	1,59	3,18	0,34	0,51

Table 18: Minimum thickness of member, edge distance and anchor spacing in masonry

FM-X5			Masonry
Minimum thickness of member	h_{min}	[mm]	$> 106^{(1)}$
Single anchor			
Minimum spacing	S_{min}	[mm]	250
Minimum edge distance	C_{min}	[mm]	100
Anchor group			
Spacing perpendicular to free edge	$S1_{min}$	[mm]	200
Spacing parallel to free edge	$S2_{min}$	[mm]	400
Minimum edge distance	C_{min}	[mm]	100

⁽¹⁾ See Annexes 7 to 14

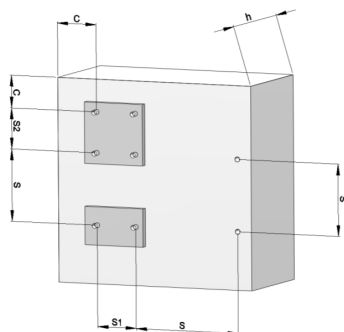
**FM-X5**

Displacements
Minimum thickness of member, edge distance and anchor spacing in masonry

Annex 15

of the European Technical Approval

ETA-10/0425

Base material: Autoclaved aerated Concrete**Table 19.1: Brick data**

Description of brick			
Type of brick			Autoclaved aerated concrete
Bulk density	$\rho \geq$	[kg/dm ³]	0,5
Standard			EN 771-4
Producer of brick			RDB Hebel S.p.A., 29010 Pontenure (PC), Italia
Format (measurement)		[mm]	$\geq 625/250/200$
Minimum thickness of member	h_{min}	[mm]	200

Table 19.2: Installation parameters

Anchor size			FM-X5 8	FM-X5 10
Drill hole diameter	d_0	[mm]	8	10
Cutting diameter of drill bit	$d_{cut} \leq$	[mm]	8,45	10,45
Depth of drill hole to deepest point	$h_1 \geq$	[mm]	80	
Drill method		[-]	Hammer drilling	
Overall plastic embedment depth	$h_{nom} =$	[mm]	70	
Diameter of clearance hole in the fixture	d_f	[mm]	8,5	10,5

Table 19.3: Characteristic resistance F_{Rk} ¹⁾ for single anchor

Anchor size			FM-X5 8	FM-X5 10
Autoclaved aerated concrete AAC 2,5 MPa	$f_b \geq$	$24^\circ\text{C}^3/40^\circ\text{C}^4$	[kN]	0,6
	Characteristic resistance F_{Rk}	$50^\circ\text{C}^3/80^\circ\text{C}^4$	[kN]	0,6
Partial safety factor	$\gamma_{AAC}^2)$	[-]	2,0	

¹⁾ Characteristic resistance F_{Rk} for tension, shear or combined tension and shear loading. The characteristic resistance is valid for single plastic anchor or for group of two or four plastic anchors with a spacing equal or larger than the minimum spacing s_{min} according to Table 21. The specific conditions for the design method have to be considered according to chapter 4.2.1.5 of the ETA.

²⁾ In absence of other national regulations

³⁾ Maximum long term temperature

⁴⁾ Maximum short term temperature

FM-X5

Autoclaved aerated concrete
Brick data, installation parameters, characteristic resistance

Annex 16

of the European Technical Approval

ETA-10/0425

Table 20: Displacements under tension and shear loading in autoclaved aerated concrete

AAC 2	Tension load			Shear load		
	F	δ_{N0}	$\delta_{N\infty}$	F	δ_{V0}	$\delta_{V\infty}$
	[kN]	[mm]	[mm]	[kN]	[mm]	[mm]
FM-X5 8	0,21	0,94	1,88	0,18	1,00	1,50
FM-X5 10	0,21	1,88	3,76	0,27	1,50	2,25

Table 21: Minimum thickness of member, edge distance and anchor spacing in autoclaved aerated concrete

FM-X5			AAC 2
Minimum thickness of member	h_{min}	[mm]	200
Single anchor			
Minimum spacing	S_{min}	[mm]	250
Minimum edge distance	C_{min}	[mm]	100
Anchor group			
Spacing perpendicular to free edge	$S1_{min}$	[mm]	200
Spacing parallel to free edge	$S2_{min}$	[mm]	400
Minimum edge distance	C_{min}	[mm]	100

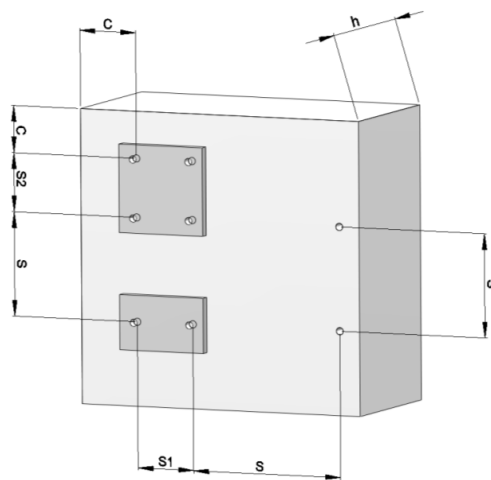

FM-X5

Autoclaved aerated concrete

Brick data, installation parameters, characteristic resistance

Annex 17

of the European Technical Approval

ETA-10/0425